

Constant current linear driver
DBL(S) Series suffix DP(DALI-2 + pushDIM+EnergyData+EL+CLO
+corridorDIM+DALI programmable)

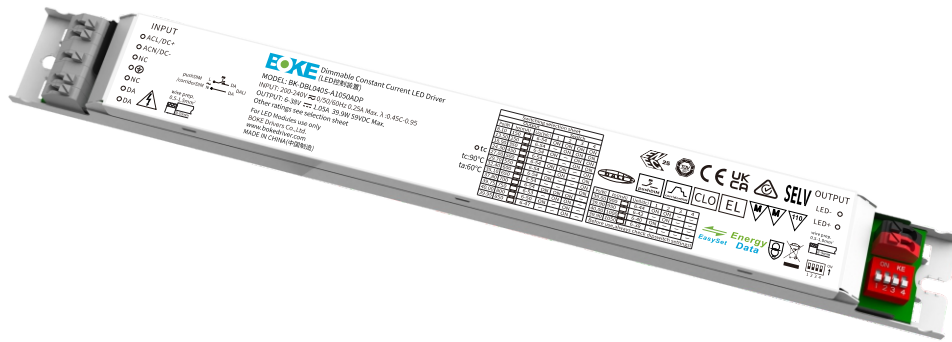

Features

- Support DALI-2+pushDIM control
- Support EnergyData function and energy-reporting reading (DALI Part 252)
- Support luminaire data reading (DALI Part 251), support diagnostics-maintenance reading (DALI Part 253)
- Support advanced functions such as corridorDIM, EL, CLO
- The output current programming can be realized through the DALI interface
- Multi-level current output can be realized by DIP-switch
- Soft dimming and flicker-free at any brightness, meets the new requirements of ErP certification
- Using HPC patented technology, at any dimming level, the brightness of the luminaries is the same
- High PF, high efficiency, low THD
- Intelligent LED hot-plug protection function
- Output Input terminal Optional press terminal
- SELV and Class I design, suitable for use inside of the luminaire
- Compliance with Zhaga Book 13 standards
- 5.5-year guarantee

Interfaces

- DALI-2 (DT6)
- PUSH (pushDIM,corridorDIM)

Functions

- Support DALI part 251,252,253
- Support central emergency application
- Support self-contained emergency application
- Emergency lighting(EL)
- Constant light output function(CLO)
- Corridor dimming(corridorDIM)
- Programming via DALI(EasySet)
- Protective features (short-circuit, overload,no-load, over temperature, hot plug-in protection)

Suitable for lights

- Suitable for linear lights,tri-proof lights,working lights, bracket lights and other linear or ultra-thin lights etc.

Typical applications

- LED indoor lighting
- LED office lighting
- LED commercial lighting



Model coding rules of DBL(S) series

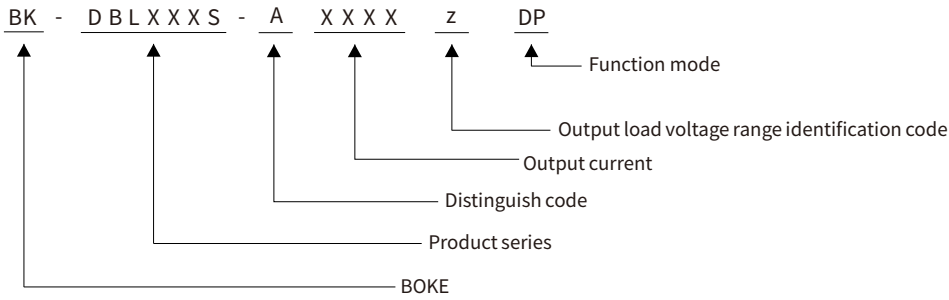

Function list

Model	Suffix	DIP-switch	Wired dimming		Advanced functions					Device Configuration	
			DALI-2	pushDIM	AOC	EL	CLO	EnergyData	corridorDIM	DALI interfaces	NFC interfaces
BK-DBL040S-A BK-DBL050S-A	DP	√	√	√	√	√	√	√	√	√	
BK-DBL060S-A BK-DBL080S-A	DN		√	√	√	√	√	√	√	√	√

*The description in this specification is only applicable to the products with the suffix DP and the model are DBL040S-A,DBL050S-A,DBL060S-A,DBL080S-A.

Model list

Model	Input voltage	Output power	Output voltage	Output current	Dimension
BK-DBL040S-A1050ADP	200-240VAC/DC	40W MAX.	6-54VDC	0.15-1.05A	L280*W30*H21mm
BK-DBL040S-A1050ADN	200-240VAC/DC	40W MAX.	6-54VDC	0.3-1.05A	L280*W30*H21mm
BK-DBL040S-A1050ADN	200-240VAC/DC	40W MAX.	6-54VDC	0.15-1.05A	L280*W30*H21mm
BK-DBL050S-A1300ADP	200-240VAC/DC	50W MAX.	6-54VDC	0.55-1.3A	L280*W30*H21mm
BK-DBL050S-A1300ADN	200-240VAC/DC	50W MAX.	6-54VDC	0.2-1.3A	L280*W30*H21mm
BK-DBL060S-A1650ADP	200-240VAC/DC	62.7W MAX.	6-54VDC	0.9-1.65A	L360*W30*H21mm
BK-DBL060S-A1650ADN	200-240VAC/DC	62.7W MAX.	6-54VDC	0.25-1.65A	L360*W30*H21mm
BK-DBL080S-A2000ADP	200-240VAC/DC	80W MAX.	6-54VDC	1.25-2A	L360*W30*H21mm
BK-DBL080S-A2000ADN	200-240VAC/DC	80W MAX.	6-54VDC	0.3-2A	L360*W30*H21mm

*The description in this specification is only applicable to the products with the suffix DP and the model are DBL040S-A,DBL050S-A,DBL060S-A,DBL080S-A.

Technical data

Product model	BK-DBL040S-A1050ADP	BK-DBL040S-A1050ADP
Output parameters		
Regulation method	Constant Current	
Rated output current range	0.15-1.05A, see the DIP-switch for details	0.3-1.05A, see the DIP-switch for details
Rated output voltage range	6-54VDC, see the DIP-switch for details	
Rated output power	40W Max, see the DIP-switch for details	
Output current adjustment	EasySet Programming/DIP S.W.(16 levels)	
Output current ripple(typ.)	±2%(78kHz)	
Output current accuracy	±2%	
Linear regulation	±1%	
Load regulation	±2%	
No load output voltage	59VDC	
Flicker-free(typ.)	Flickering percent(IEEE 1789)=0.186%(100Hz), Flicker index(IEEE 1789)=0.001(100Hz), Pst LM = 0.001, SVM = 0.005, (The above parameters are obtained from testing the panel lights)	
Input parameters		
Rated input voltage range	200-240VAC 200-240VDC	
Input voltage range	180-264VAC 180-264VDC	
Input voltage shock	<380 VAC	
Input current	<0.25A (Rated input voltage)	
Input frequency	0/50/60Hz	
Input PF/Input DF(typ.)	PF: 0.98, DF: 0.98 , see the electrical values below for details	
Input THD(typ.)	10% , see the electrical values below for details	
Efficiency(typ.)	90% , see the electrical values below for details	
In-rush current(typ.)	6.6A peak, 189us duration(50% Ipeak), see the description below for details	
Start/Switchover/Turn off	<0.75s(AC start), <0.75s(DC start), <0.3s(AC/DC switchover), <0.5s(Turn off)	
Switching cycles	> 100,000 switching cycles	
Power consumption(typ.)	Full load(Pin):44.4W, No load(Pno): N/A, On stand-by(Psb) : <0.5W, Network stand-by(Pnet) : N/A	
Safety		
Withstand voltage	I/P-O/P:3750VAC, I/P-FG:1750VAC, O/P-FG:500VAC , I/P-DALI: 1500VAC, O/P-DALI: 1500VAC	
Mains surge capability	L-N:2KV, L-FG/N-FG:4KV(90°/270°, 5 times each with an interval of 60s)(Performance criterion:B)	
Leakage current(typical)	0.53mA	
Isolation resistance	I/P-O/P:100MΩ/500Vdc/25°C/70%RH	
Control interface		
DALI dimming port	Voltage range: 9.5-22.5V, typical 16V, interface current consumption: 1.8mA	
pushDIM dimming port	Voltage range: 180-264V 47/63Hz	
1-10V 3in1 dimming port	N/A	
Auxiliary power supply	N/A	
Dimming range	0.1%-100%(Minimum current:1mA)	
Dimming drive mode	AM(amplitude modulation)	
Emergency support		
Central emergency system	Supported	
Self-contained emergency	Supported	
Environment & Life time		
Operating temperature	Ta=-25-60°C	
Case temperature	Tc=90°C	
Operating humidity	5-85% RH, non-condensing	
Storage temp./humidity	-40-80°C, 5-85% RH, non-condensing	
IP grade	IP20	
MTBF	500,000H, MIL-HDBK-217F(25°C)	
Life-time	Nominal life-time up to 100,000 h, see the description below for details	
Vibration resistant	10~500Hz, 5G 12min./1cycle, period for 72min. each along X,Y,Z axes	
Acoustic Noise	<25dB(30cm, Normal operation)	
Environmental protection	RoHS	
Certifications and standards		
Compliance certification	CE, ENEC, UKCA, RCM, CCC, DALI-2, EL	
Safety	GB/T 19510.1, GB/T 19510.213, EN61347-1, EN61347-2-13, EN62384	
EMC	GB/T 17743, GB17625.1, EN55015, EN61000-3-2, EN61000-3-3, EN61000-4-2,3,4,5,6,8,11, EN61547	
DALI-2	IEC 62386-101(DALI-2), IEC 62386-102(DALI-2), IEC 62386-207(DALI-2), DALI part251,252,253	
EL	Compatible IEC 61347-2-13 Annex J, compatible with EN 60598-2-22 and EN 50172	
RF	N/A	

Remarks

1. By default, all parameter are measured at 230VAC input, 50Hz, full load and 25°C of ambient temperature.

Technical data

Product model	BK-DBL050S-A1300ADP
Output parameters	
Regulation method	Constant Current
Rated output current range	0.55-1.3A, see the DIP-switch for details
Rated output voltage range	6-54VDC, see the DIP-switch for details
Rated output power	50W Max, see the DIP-switch for details
Output current adjustment	EasySet Programming/DIP S.W.(16 levels)
Output current ripple(typ.)	±2%(74kHz)
Output current accuracy	±2%
Linear regulation	±1%
Load regulation	±2%
No load output voltage	59VDC
Flicker-free(typ.)	Flickering percent(IEEE 1789)=0.194%(100Hz), Flicker index(IEEE 1789)=0.001(100Hz), Pst LM = 0.000, SVM = 0.005, (The above parameters are obtained from testing the panel lights)
Input parameters	
Rated input voltage range	200-240VAC 200-240VDC
Input voltage range	180-264VAC 180-264VDC
Input voltage shock	<380 VAC
Input current	<0.31A (Rated input voltage)
Input frequency	0/50/60Hz
Input PF/Input DF(typ.)	PF: 0.98, DF: 0.98, see the electrical values below for details
Input THD(typ.)	10%, see the electrical values below for details
Efficiency(typ.)	90%, see the electrical values below for details
In-rush current(typ.)	8.85A peak, 204us duration(50% Ipeak), see the description below for details
Start/Switchover/Turn off	<0.75s(AC start), <0.75s(DC start), <0.3s(AC/DC switchover), <0.5s(Turn off)
Switching cycles	> 100,000 switching cycles
Power consumption(typ.)	Full load(Pin):55.6W, No load(Pno): N/A, On stand-by(Psb): <0.5W, Network stand-by(Pnet): N/A
Safety	
Withstand voltage	I/P-O/P:3750VAC, I/P-FG:1750VAC, O/P-FG:500VAC, I/P-DALI: 1500VAC, O/P-DALI: 1500VAC
Mains surge capability	L-N:2KV, L-FG/N-FG:4KV(90°/270°, 5 times each with an interval of 60s)(Performance criterion:B)
Leakage current(typical)	0.86mA
Isolation resistance	I/P-O/P:100MΩ/500Vdc/25°C/70%RH
Control interface	
DALI dimming port	Voltage range: 9.5-22.5V, typical 16V, interface current consumption: 1.8mA
pushDIM dimming port	Voltage range: 180-264V 47/63Hz
1-10V 3in1 dimming port	N/A
Auxiliary power supply	N/A
Dimming range	0.1%-100%(Minimum current:1.3mA)
Dimming drive mode	AM(amplitude modulation)
Emergency support	
Central emergency system	Supported
Self-contained emergency	Supported
Environment & Life time	
Operating temperature	Ta=-25-60°C
Case temperature	Tc=90°C
Operating humidity	5-85% RH, non-condensing
Storage temp./humidity	-40-80°C, 5-85% RH, non-condensing
IP grade	IP20
MTBF	500,000H, MIL-HDBK-217F(25°C)
Life-time	Nominal life-time up to 100,000 h, see the description below for details
Vibration resistant	10~500Hz, 5G 12min./1cycle, period for 72min. each along X,Y,Z axes
Acoustic Noise	<25dB(30cm, Normal operation)
Environmental protection	RoHS
Certifications and standards	
Compliance certification	CE, ENEC, UKCA, RCM, CCC, DALI-2, EL
Safety	GB/T 19510.1, GB/T 19510.213, EN61347-1, EN61347-2-13, EN62384
EMC	GB/T 17743, GB17625.1, EN55015, EN61000-3-2, EN61000-3-3, EN61000-4-2,3,4,5,6,8,11, EN61547
DALI-2	IEC 62386-101(DALI-2), IEC 62386-102(DALI-2), IEC 62386-207(DALI-2), DALI part251,252,253
EL	Compatible IEC 61347-2-13 Annex J, compatible with EN 60598-2-22 and EN 50172
RF	N/A

Remarks

1. By default, all parameter are measured at 230VAC input, 50Hz, full load and 25°C of ambient temperature.

Technical data

Product model	BK-DBL060S-A1650ADP
Output parameters	
Regulation method	Constant Current
Rated output current range	0.9-1.65A, see the DIP-switch for details
Rated output voltage range	6-54VDC, see the DIP-switch for details
Rated output power	62.7W Max, see the DIP-switch for details
Output current adjustment	EasySet Programming/DIP S.W(16 levels)
Output current ripple(typ.)	±2%(112kHz)
Output current accuracy	±2%
Linear regulation	±1%
Load regulation	±2%
No load output voltage	59VDC
Flicker-free(typ.)	Flickering percent(IEEE 1789)=0.076%(100Hz), Flicker index(IEEE 1789)=0.001(100Hz), Pst LM = 0.017, SVM = 0.002, (The above parameters are obtained from testing the panel lights)
Input parameters	
Rated input voltage range	200-240VAC 200-240VDC
Input voltage range	180-264VAC 180-264VDC
Input voltage shock	<380 VAC
Input current	<0.4A (Rated input voltage)
Input frequency	0/50/60Hz
Input PF/Input DF(typ.)	PF: 0.98, DF: 0.98 , see the electrical values below for details
Input THD(typ.)	10% , see the electrical values below for details
Efficiency(typ.)	91% , see the electrical values below for details
In-rush current(typ.)	11.3A peak ,188us duration(50 % Ipeak), see the description below for details
Start/Switchover/Turn off	<0.75s(AC start), <0.75s(DC start), <0.3s(AC/DC switchover), <0.5s(Turn off)
Switching cycles	> 100,000 switching cycles
Power consumption(typ.)	Full load(Pin):68.9W, No load(Pno): N/A, On stand-by(Psb) : <0.5W, Network stand-by(Pnet) : N/A
Safety	
Withstand voltage	I/P-O/P:3750VAC,I/P-FG:1750VAC,O/P-FG:500VAC ,I/P-DALI: 1500VAC,O/P-DALI: 1500VAC
Mains surge capability	L-N:2KV,L-FG/N-FG:4KV(90°/270° , 5 times each with an interval of 60s)(Performance criterion:B)
Leakage current(typical)	0.78mA
Isolation resistance	I/P-O/P:100MΩ/500Vdc/25°C/70%RH
Control interface	
DALI dimming port	Voltage range: 9.5-22.5V, typical 16V, interface current consumption: 1.8mA
pushDIM dimming port	Voltage range: 180-264V 47/63Hz
1-10V 3in1 dimming port	N/A
Auxiliary power supply	N/A
Dimming range	0.1%-100%(Minimum current:1.6mA)
Dimming drive mode	AM(amplitude modulation)
Emergency support	
Central emergency system	Supported
Self-contained emergency	Supported
Environment & Life time	
Operating temperature	Ta=-25-60°C
Case temperature	Tc=90°C
Operating humidity	5-85% RH, non-condensing
Storage temp./humidity	-40-80°C, 5-85% RH, non-condensing
IP grade	IP20
MTBF	500,000H,MIL-HDBK-217F(25°C)
Life-time	Nominal life-time up to 100,000 h, see the description below for details
Vibration resistant	10~500Hz,5G 12min./1cycle,period for 72min. each along X,Y,Z axes
Acoustic Noise	<25dB(30cm, Normal operation)
Environmental protection	RoHS
Certifications and standards	
Compliance certification	CE, ENEC, UKCA, RCM, CCC, DALI-2, EL
Safety	GB/T 19510.1,GB/T 19510.213, EN61347-1, EN61347-2-13, EN62384
EMC	GB/T 17743 , GB17625.1, EN55015, EN61000-3-2 , EN61000-3-3, EN61000-4-2,3,4,5,6,8,11, EN61547
DALI-2	IEC 62386-101(DALI-2), IEC 62386-102(DALI-2), IEC 62386-207(DALI-2), DALI part251,252,253
EL	Compatible IEC 61347-2- 13 Annex J, compatible with EN 60598-2-22 and EN 50172
RF	N/A

Remarks

1.By default, all parameter are measured at 230VAC input, 50Hz, full load and 25°C of ambient temperature.

Technical data

Product model	BK-DBL080S-A2000ADP
Output parameters	
Regulation method	Constant Current
Rated output current range	1.25-2A, see the DIP-switch for details
Rated output voltage range	6-54VDC, see the DIP-switch for details
Rated output power	80W Max, see the DIP-switch for details
Output current adjustment	EasySet Programming/DIP S.W.(16 levels)
Output current ripple (typ.)	±2%(80.5kHz)
Output current accuracy	±1%
Linear regulation	±2%
Load regulation	±2%
No load output voltage	59VDC
Flicker-free (typ.)	Flickering percent(IEEE 1789)=0.107%(100Hz), Flicker index(IEEE 1789)=0.001(100Hz), Pst LM = 0.028, SVM = 0.001, (The above parameters are obtained from testing the panel lights)
Input parameters	
Rated input voltage range	200-240VAC 200-240VDC
Input voltage range	180-264VAC 180-264VDC
Input voltage shock	<380 VAC
Input current	<0.51A (Rated input voltage)
Input frequency	0/50/60Hz
Input PF/Input DF (typ.)	PF: 0.98, DF: 0.98, see the electrical values below for details
Input THD (typ.)	10%, see the electrical values below for details
Efficiency (typ.)	91%, see the electrical values below for details
In-rush current (typ.)	12.75A peak, 208us duration (50% I _{peak}), see the description below for details
Start/Switchover/Turn off	<0.75s(AC start), <0.75s(DC start), <0.3s(AC/DC switchover), <0.5s(Turn off)
Switching cycles	> 100,000 switching cycles
Power consumption (typ.)	Full load(P _{in}):87.9W, No load(P _{no}): N/A, On stand-by(P _{sb}): <0.5W, Network stand-by(P _{net}): N/A
Safety	
Withstand voltage	I/P-O/P:3750VAC, I/P-FG:1750VAC, O/P-FG:500VAC, I/P-DALI: 1500VAC, O/P-DALI: 1500VAC
Mains surge capability	L-N:2KV, L-FG/N-FG:4KV(90°/270°, 5 times each with an interval of 60s)(Performance criterion:B)
Leakage current (typical)	0.65mA
Isolation resistance	I/P-O/P:100MΩ/500Vdc/25°C/70%RH
Control interface	
DALI dimming port	Voltage range: 9.5-22.5V, typical 16V, interface current consumption: 1.8mA
pushDIM dimming port	Voltage range: 180-264V 47/63Hz
1-10V 3in1 dimming port	N/A
Auxiliary power supply	N/A
Dimming range	0.1%-100%(Minimum current:2mA)
Dimming drive mode	AM(amplitude modulation)
Emergency support	
Central emergency system	Supported
Self-contained emergency	Supported
Environment & Life time	
Operating temperature	T _a =-25-60°C
Case temperature	T _c =90°C
Operating humidity	5-85% RH, non-condensing
Storage temp./humidity	-40-80°C, 5-85% RH, non-condensing
IP grade	IP20
MTBF	500,000H, MIL-HDBK-217F(25°C)
Life-time	Nominal life-time up to 100,000 h, see the description below for details
Vibration resistant	10~500Hz, 5G 12min./1cycle, period for 72min. each along X,Y,Z axes
Acoustic Noise	<25dB(30cm, Normal operation)
Environmental protection	RoHS
Certifications and standards	
Compliance certification	CE, ENEC, UKCA, RCM, CCC, DALI-2, EL
Safety	GB/T 19510.1, GB/T 19510.213, EN61347-1, EN61347-2-13, EN62384
EMC	GB/T 17743, GB17625.1, EN55015, EN61000-3-2, EN61000-3-3, EN61000-4-2,3,4,5,6,8,11, EN61547
DALI-2	IEC 62386-101(DALI-2), IEC 62386-102(DALI-2), IEC 62386-207(DALI-2), DALI part251,252,253
EL	Compatible IEC 61347-2-13 Annex J, compatible with EN 60598-2-22 and EN 50172
RF	N/A

Remarks

1. By default, all parameter are measured at 230VAC input, 50Hz, full load and 25°C of ambient temperature.

Electrical values

BK-DBL040S-A

Efficiency vs load

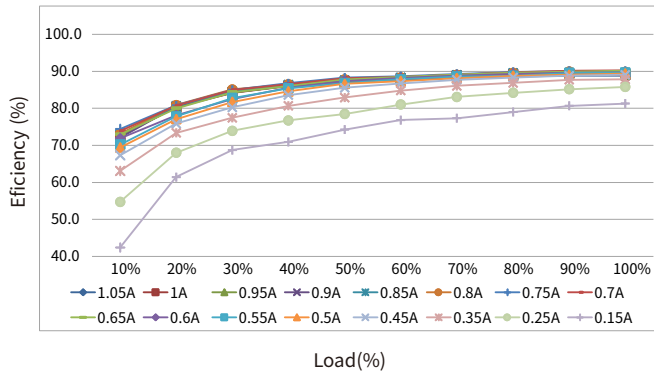

THD vs. Load

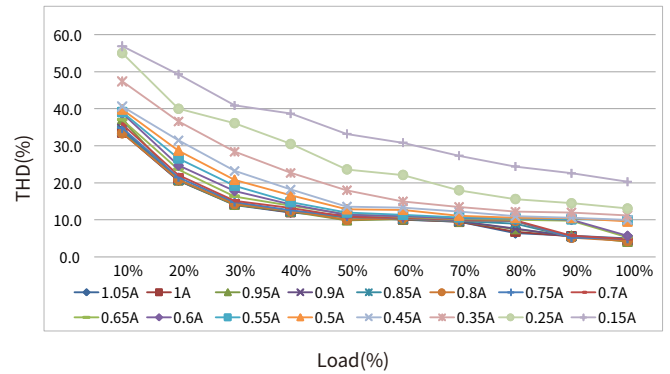

Power factor vs. Load

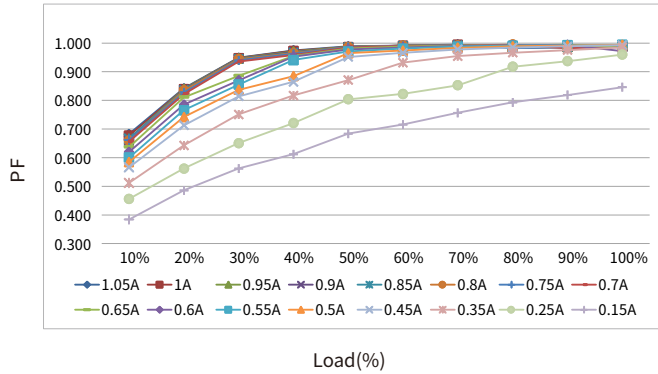

Displacement factor vs. Load

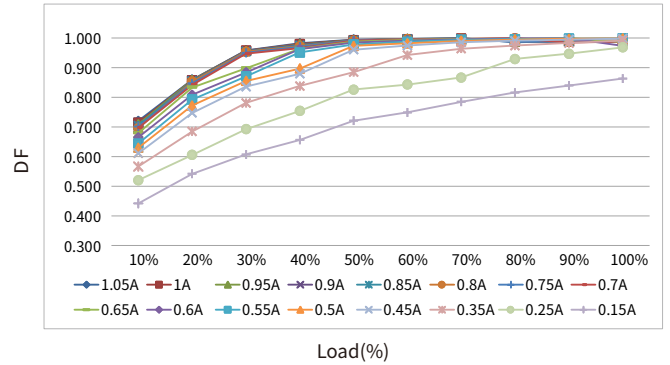

Expected life-time

Life-time vs. case temperature

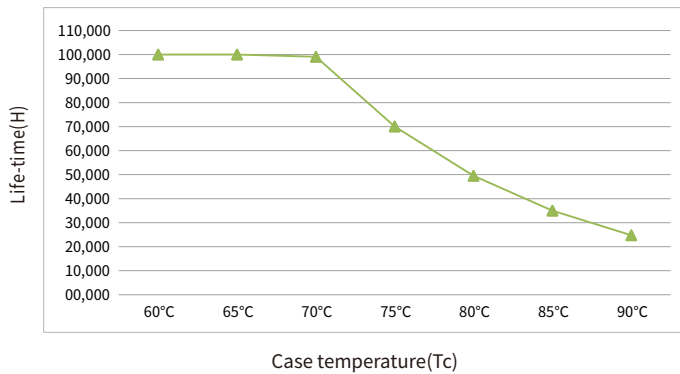

-The life-time of the LED driver is shown in the figure above (calculated based on the 90% survival rate).

- The relation of tc to ta temperature depends also on the luminaire design.

Electrical values

BK-DBL050S-A

Efficiency vs load

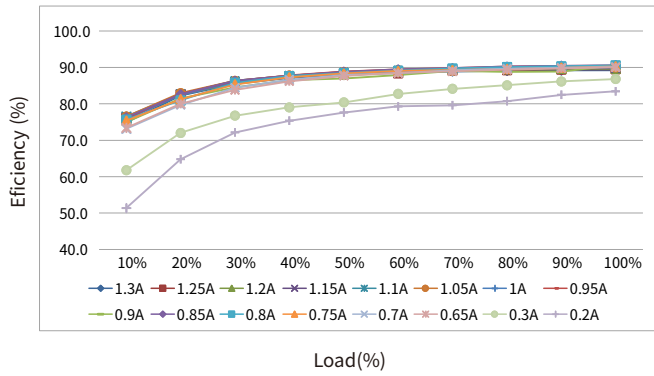

THD vs. Load

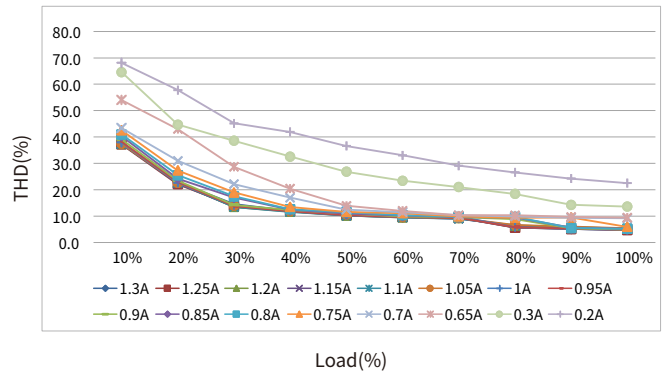

Power factor vs. Load

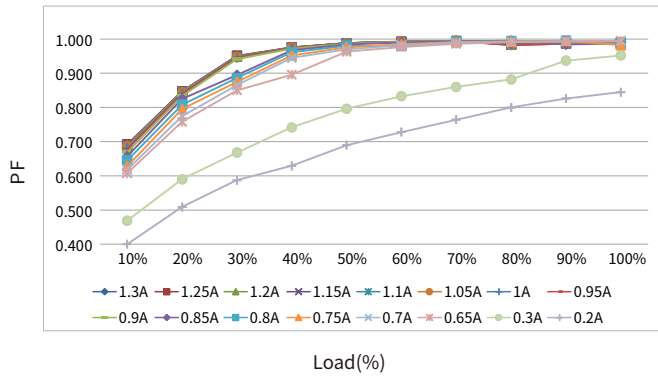

Displacement factor vs. Load

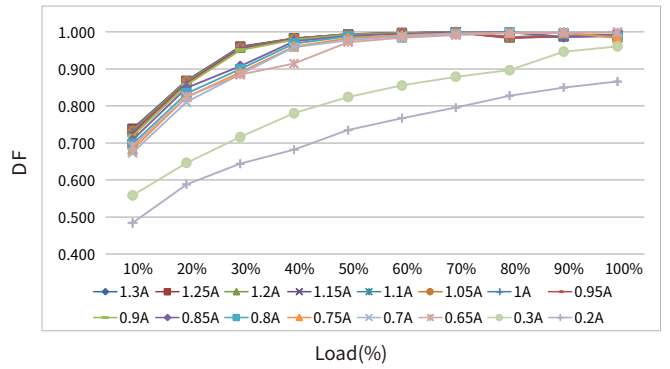

Expected life-time

Life-time vs. case temperature

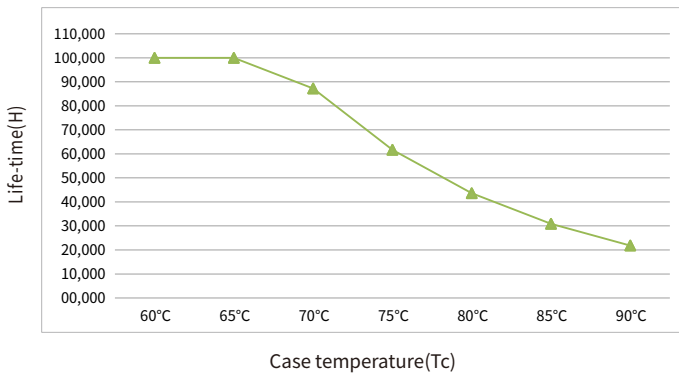

-The life-time of the LED driver is shown in the figure above (calculated based on the 90% survival rate).

- The relation of tc to ta temperature depends also on the luminaire design.

Electrical values

BK-DBL060S-A

Efficiency vs load

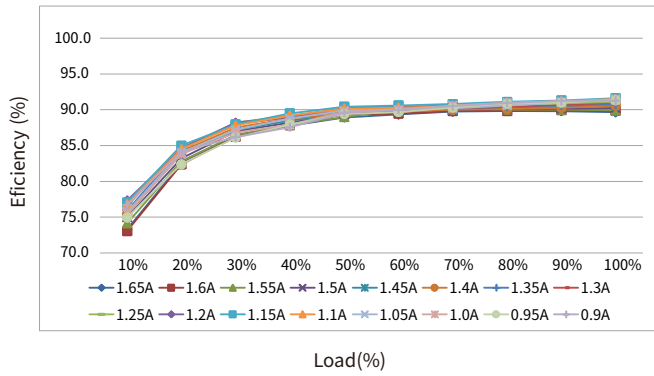

THD vs. Load

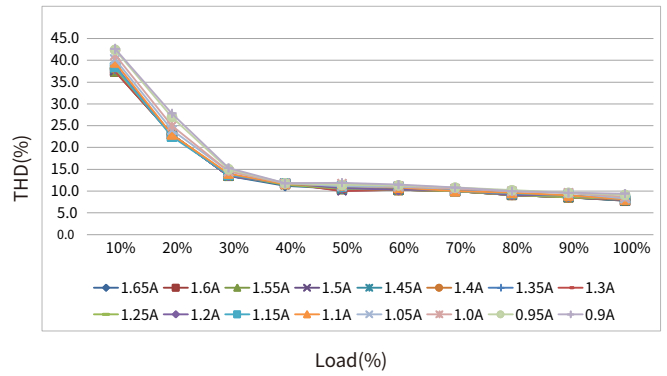

Power factor vs. Load

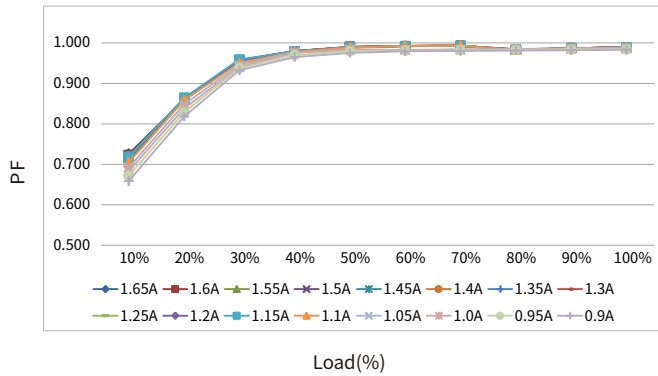

Displacement factor vs. Load

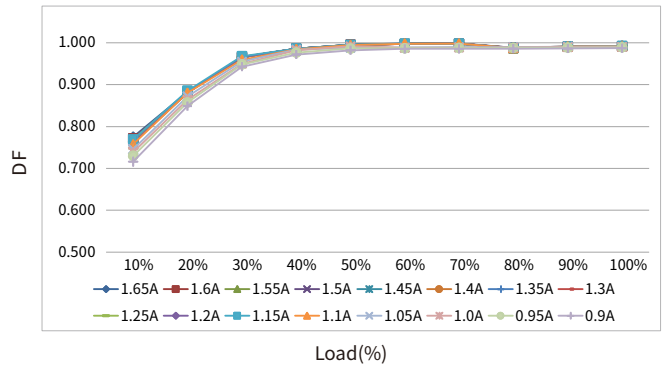

Expected life-time

Life-time vs. case temperature

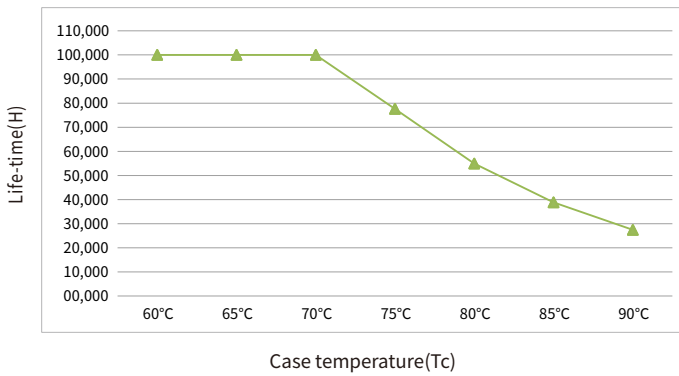

-The life-time of the LED driver is shown in the figure above (calculated based on the 90% survival rate).

- The relation of tc to ta temperature depends also on the luminaire design.

Electrical values

BK-DBL080S-A

Efficiency vs load

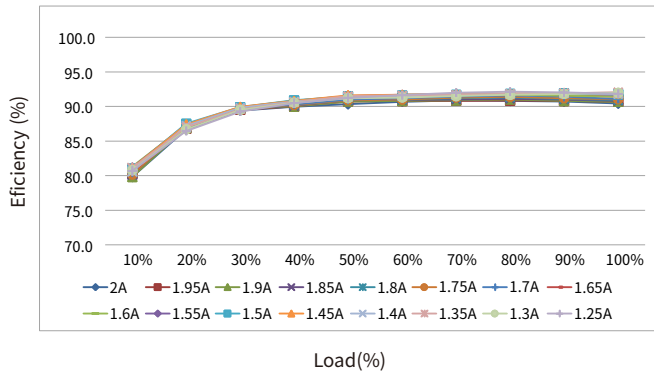

THD vs. Load

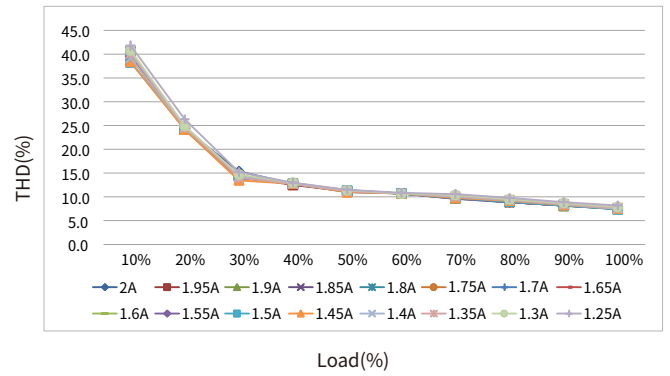

Power factor vs. Load

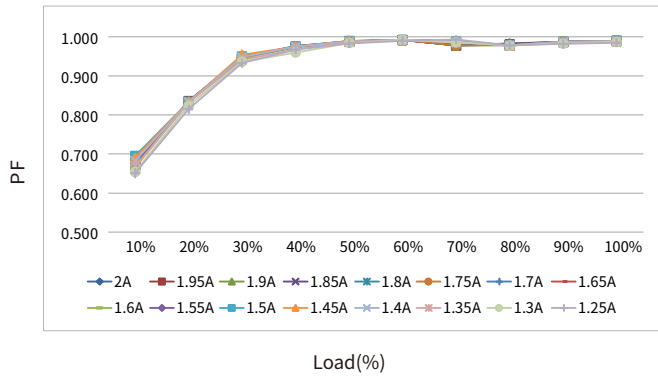

Displacement factor vs. Load

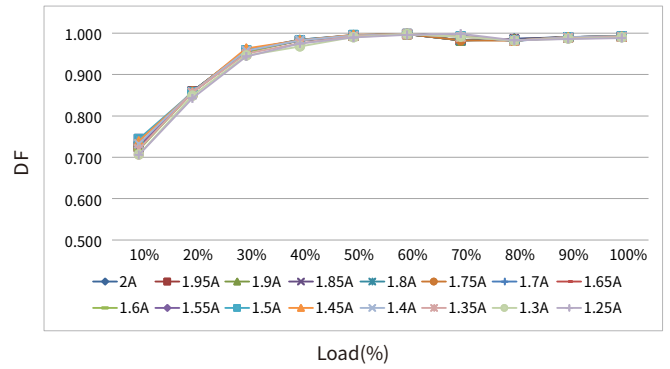

Expected life-time

Life-time vs. case temperature

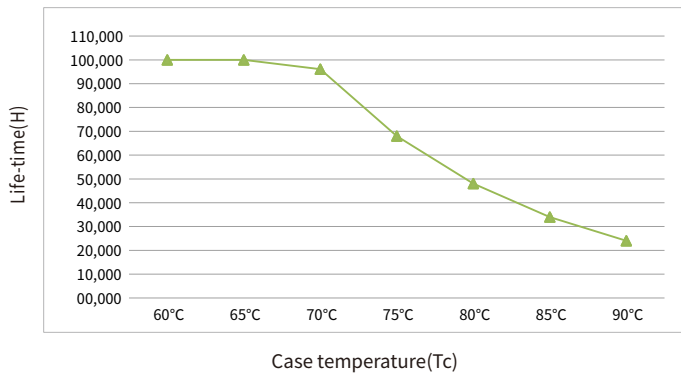

-The life-time of the LED driver is shown in the figure above (calculated based on the 90% survival rate).

- The relation of tc to ta temperature depends also on the luminaire design.

Surge

Model	Ipeak	Twidth	Condition	Relative number of MCB														
				B10	B13	B16	B20	B25	C10	C13	C16	C20	C25	D10	D13	D16	D20	D25
BK-DBL040S-A	6.6A	189us	AC 230V, Full load, Cold start, Ta ≤ 30°C, MCB is not installed side by side	40	52	64	80	100	40	52	64	80	100	40	52	64	80	100
BK-DBL050S-A	8.85A	204us		33	42	52	65	81	33	42	52	65	81	33	42	52	65	81
BK-DBL060S-A	11.3A	188us		26	34	41	52	65	26	34	41	52	65	26	34	41	52	65
BK-DBL080S-A	12.75A	208us		20	26	32	41	51	20	26	32	41	51	20	26	32	41	51

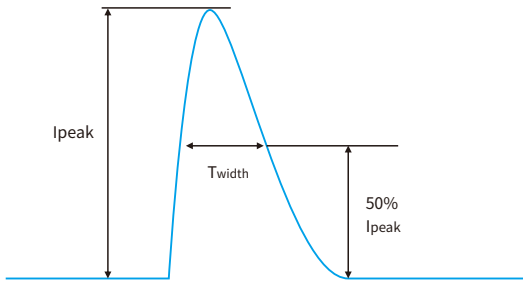

Remarks

- The number of drives mounted under different MCBs in the table is the maximum value. Please do not exceed this number during installation.
- Calculation uses typical values from ABB series S200 as a reference.
- Different brands and models of miniature circuit breakers, the number of drives mounted will be slightly different.
- If the ambient temperature of the MCB installation exceeds 30°C or multiple MCBs are installed side by side, the number of drives mounted will be reduced and the calculation needs to be recalculated.
- Electrician's usually consider Type B for household lighting and Type C for commercial lighting application.

Functions

Output short-circuit behaviour

- Output short-circuit will not damage the driver. After removing the short circuit fault, the driver will automatically resume output.

Output no-load operation

- Output no-load will not damage the driver. Please turn off the driver first if you need to connect the LED load.

Output overload protection

- The LED driver turns off the output if the output voltage range is exceeded. The output will be activated again after restart the LED driver.

Output over temperature

- When the operating temperature exceeds the over temperature protection point inside the power supply IC, the power supply enters protection state such as output derating, output hiccup or output shutdown. After the external temperature is normal, restart and resume operation.

Output hot plug-in protection

- This function is used to prevent LED light that are far below the driver's no-load voltage burnout when hot plugged into a powered driver output.
- This function can be enabled or disabled through the programming interface. If enabled, when the LED light is connected to the powered driver, the LED light will not light up, you can restart the drive to restore normal. If disabled, when the LED light is connected to the powered driver, the LED light will turn on or off according to the current brightness level.
- Please refer to the parameters configure in the "Device configuration" section for information on whether the default factory settings are enabled.
- Factory default Enabled or not please check the "Device configuration" section.

- Note:

When the hot plug-in protection is enable, the following applications may not achieve the expected effect:

1. When the output of the driver is connected to the color temperature switch: When the switch is used to change the color temperature, the hot plug-in protection of the driver will be triggered, and the LED will not be lit.
2. When the LED driver is used in conjunction with a self-contained (independent) emergency control device: Use the self-check test switch of the emergency control device to test the emergency function and when exiting the emergency mode, the driver's hot plug-in protection will be triggered and the LED will not be lit. The above two application drivers should turn off the hot plug-in protection function in order to achieve good working results.

Driver restart method

There are two ways to restart the driver:

- Through the AC input: disconnect the AC of the driver and power it again.
- Through dimming interface. DALI: send "OFF" command first, then send "MAX" command. pushDIM: short press pushbutton two times, then long press pushbutton.

Adjustable output current (AOC)

- The output current of the driver can be adjusted within a certain range, and 2 options can be selected through the EasySet configuration software.

Setting 1 (default): By DIP-switch setting

The output current is determined by the selection of the DIP-switch.

Setting 2: By programming setting

The output current is determined by the programming setting.

Corridor dimming (corridorDIM)

- Please see the "corridorDIM dimming" section.

Constant light output (CLO)

- The luminous flux of a LED decreases constantly over the life-time.
- The CLO function ensures that the emitted luminous flux remains stable. For that purpose the LED current will increase continuously over the LED life-time.
- In EasySet configuration it is possible to select a start value (in percent) and an expected life-time. The LED driver adjusts the current afterwards automatically.

Emergency lighting (EL)

- The driver works normally under DC input.
- When the driver is applied in DC input, the positive pole of the DC cable should be connected to the ACL/DC+ terminal, and the negative pole of the DC cable should be connected to the ACN/DC- terminal. If the connection is reversed, the driver will not be damaged, but it will affect the EL function normal work.
- The output response action after DC input can be set through the EasySet configuration software. Setting 1: When DC input, the output of the driver remains unchanged, and the dimming function responds normally. Setting 2 (default): When DC input, the output of the driver jumps to the set brightness of 15%, and the dimming function is invalid.

Configuration programming (EasySet)

- The programming configuration of the driver is realized using the BOKE EasySet programming suite and through the driver's DALI interface.
- Please see the "Device configuration" section.
- More information about the EasySet programming suite can be found at www.bokedriver.com.

Insulation between circuits

Isolation	Input	Output	Case	DALI	PUSH
Input	-	Double	Basic	Basic	-
Output	Double	-	Basic	Basic	Double
Case	Basic	Basic	-	Basic	Basic

Label

BK-DBL040S-A1050ADP

INPUT
 ○ ACL/DC+
 ○ ACN/DC-
 ○ NC
 ○ NC
 ○ NC
 ○ DA
 ○ DA

BOKE Dimmable Constant Current LED Driver (LED控制装置)
 MODEL: BK-DBL040S-A1050ADP
 INPUT: 200-240V \approx 0.50/60Hz 0.25A Max. λ : 0.45C-0.95
 OUTPUT: 6-38V \approx 1.05A 39.9W 59VDC Max.
 Other ratings see selection sheet
 For LED Modules use only
 BOKE Drivers Co., Ltd.
 www.bokedriver.com
 MADE IN CHINA(中国制造)

Switching selection sheet

Output	1	2	3	4
Po(w)	16.20	18.90	21.60	24.30
Io(mA)	150	350	450	550
Uo(Vdc)	6-54	6-54	6-54	6-54

0 t_c:90°C
 ta:60°C

CE, UK, SELV, Energy Data, EasySet, CLO, EL, W/M, V10

INPUT
 ○ ACL/DC+
 ○ ACN/DC-
 ○ NC
 ○ NC
 ○ NC
 ○ DA
 ○ DA

BOKE Dimmable Constant Current LED Driver (LED控制装置)
 MODEL: BK-DBL040S-A1050ADP
 INPUT: 200-240V \approx 0.50/60Hz 0.25A Max. λ : 0.45C-0.95
 OUTPUT: 6-38V \approx 1.05A 39.9W 59VDC Max.
 Other ratings see selection sheet
 For LED Modules use only
 BOKE Drivers Co., Ltd.
 www.bokedriver.com
 MADE IN CHINA(中国制造)

Switching selection sheet

Output	1	2	3	4
Po(w)	16.20	18.90	21.60	24.30
Io(mA)	150	350	450	550
Uo(Vdc)	6-54	6-54	6-54	6-54

0 t_c:90°C
 ta:60°C

CE, UK, SELV, Energy Data, EasySet, CLO, EL, W/M, V10

BK-DBL050S-A1300ADP

INPUT
 ○ ACL/DC+
 ○ ACN/DC-
 ○ NC
 ○ NC
 ○ NC
 ○ DA
 ○ DA

BOKE Dimmable Constant Current LED Driver (LED控制装置)
 MODEL: BK-DBL050S-A1300ADP
 INPUT: 200-240V \approx 0.50/60Hz 0.31A Max. λ : 0.45C-0.95
 OUTPUT: 6-38V \approx 1.3A 49.4W 59VDC Max.
 Other ratings see selection sheet
 For LED Modules use only
 BOKE Drivers Co., Ltd.
 www.bokedriver.com
 MADE IN CHINA(中国制造)

Switching selection sheet

Output	1	2	3	4
Po(w)	18.90	21.60	24.30	27.00
Io(mA)	350	450	550	650
Uo(Vdc)	6-54	6-54	6-54	6-54

0 t_c:90°C
 ta:60°C

CE, UK, SELV, Energy Data, EasySet, CLO, EL, W/M, V10

BK-DBL060S-A1650ADP

INPUT
 ○ ACL/DC+
 ○ ACN/DC-
 ○ NC
 ○ NC
 ○ NC
 ○ DA
 ○ DA

BOKE Dimmable Constant Current LED Driver (LED控制装置)
 MODEL: BK-DBL060S-A1650ADP
 INPUT: 200-240V \approx 0.50/60Hz 0.44A Max. λ : 0.45C-0.95
 OUTPUT: 6-38V \approx 1.65A 62.7W 59VDC Max.
 Other ratings see selection sheet
 For LED Modules use only
 BOKE Drivers Co., Ltd.
 www.bokedriver.com
 MADE IN CHINA(中国制造)

Switching selection sheet

Output	1	2	3	4
Po(w)	21.60	24.30	27.00	29.70
Io(mA)	450	550	650	750
Uo(Vdc)	6-54	6-54	6-54	6-54

0 t_c:90°C
 ta:60°C

CE, UK, SELV, Energy Data, EasySet, CLO, EL, W/M, V10

BK-DBL080S-A2000ADP

INPUT
 ○ ACL/DC+
 ○ ACN/DC-
 ○ NC
 ○ NC
 ○ NC
 ○ DA
 ○ DA

BOKE Dimmable Constant Current LED Driver (LED控制装置)
 MODEL: BK-DBL080S-A2000ADP
 INPUT: 200-240V \approx 0.50/60Hz 0.51A Max. λ : 0.45C-0.95
 OUTPUT: 6-40V \approx 1.8A 80W 59VDC Max.
 Other ratings see selection sheet
 For LED Modules use only
 BOKE Drivers Co., Ltd.
 www.bokedriver.com
 MADE IN CHINA(中国制造)

Switching selection sheet

Output	1	2	3	4
Po(w)	24.30	27.00	29.70	32.40
Io(mA)	650	750	850	950
Uo(Vdc)	6-44	6-44	6-44	6-44

0 t_c:90°C
 ta:60°C

CE, UK, SELV, Energy Data, EasySet, CLO, EL, W/M, V10

DIP-switch & output current

BK-DBL040S-A1050ADP

Prated(w)	Irated(mA)	Voltage(Vdc)	Output			
			1	2	3	4
8.10	150	6-54	ON	ON	ON	ON
13.50	250	6-54	--	ON	ON	ON
18.90	350	6-54	ON	--	ON	ON
24.30	450	6-54	--	--	ON	ON
27.00	500	6-54	ON	ON	--	ON
29.70	550	6-54	--	ON	--	ON
32.40	600	6-54	ON	--	--	ON
35.10	650	6-54	--	--	--	ON
37.80	700	6-54	ON	ON	ON	--
39.75	750	6-53	--	ON	ON	--
40.00	800	6-50	ON	--	ON	--
39.95	850	6-47	--	--	ON	--
39.60	900	6-44	ON	ON	--	--
39.90	950	6-42	--	ON	--	--
40.00	1000	6-40	ON	--	--	--
39.90	1050	6-38	--	--	--	--

BK-DBL040S-A1050ADP

Po(w)	Io(mA)	Uo(Vdc)	Output			
			1	2	3	4
16.20	300	6-54	ON	ON	ON	ON
18.90	350	6-54	--	ON	ON	ON
21.60	400	6-54	ON	--	ON	ON
24.30	450	6-54	--	--	ON	ON
27.00	500	6-54	ON	ON	--	ON
29.70	550	6-54	--	ON	--	ON
32.40	600	6-54	ON	--	--	ON
35.10	650	6-54	--	--	--	ON
37.80	700	6-54	ON	ON	ON	--
39.75	750	6-53	--	ON	ON	--
40.00	800	6-50	ON	--	ON	--
39.95	850	6-47	--	--	ON	--
39.60	900	6-44	ON	ON	--	--
39.90	950	6-42	--	ON	--	--
40.00	1000	6-40	ON	--	--	--
39.90	1050	6-38	--	--	--	--

DIP-switch & output current

BK-DBL050S-A1300ADP

Output			1	2	3	4
Prated(w)	Irated(mA)	Voltage(Vdc)				
29.70	550	6-54	ON	ON	ON	ON
32.40	600	6-54	--	ON	ON	ON
35.10	650	6-54	ON	--	ON	ON
37.80	700	6-54	--	--	ON	ON
40.50	750	6-54	ON	ON	--	ON
43.20	800	6-54	--	ON	--	ON
45.90	850	6-54	ON	--	--	ON
48.60	900	6-54	--	--	--	ON
49.40	950	6-52	ON	ON	ON	--
50.00	1000	6-50	--	ON	ON	--
49.35	1050	6-45	ON	--	ON	--
49.50	1100	6-43	--	--	ON	--
49.45	1150	6-42	ON	ON	--	--
49.20	1200	6-41	--	ON	--	--
50.00	1250	6-40	ON	--	--	--
49.40	1300 ★	6-38	--	--	--	--

BK-DBL060S-A1650ADP

Output			1	2	3	4
Prated(w)	Irated(mA)	Voltage(Vdc)				
48.60	900	6-54	ON	ON	ON	ON
51.30	950	6-54	--	ON	ON	ON
54.00	1000	6-54	ON	--	ON	ON
56.70	1050	6-54	--	--	ON	ON
59.40	1100	6-54	ON	ON	--	ON
62.10	1150	6-54	--	ON	--	ON
62.40	1200	6-52	ON	--	--	ON
62.50	1250	6-50	--	--	--	ON
62.40	1300	6-48	ON	ON	ON	--
62.10	1350	6-46	--	ON	ON	--
61.60	1400	6-44	ON	--	ON	--
62.35	1450	6-43	--	--	ON	--
61.50	1500	6-41	ON	ON	--	--
62.00	1550	6-40	--	ON	--	--
62.40	1600	6-39	ON	--	--	--
62.70	1650 ★	6-38	--	--	--	--

BK-DBL080S-A2000ADP

Output			1	2	3	4
Prated(w)	Irated(mA)	Voltage(Vdc)				
67.50	1250	6-54	ON	ON	ON	ON
70.20	1300	6-54	--	ON	ON	ON
72.90	1350	6-54	ON	--	ON	ON
75.60	1400	6-54	--	--	ON	ON
78.30	1450	6-54	ON	ON	--	ON
79.50	1500	6-53	--	ON	--	ON
79.05	1550	6-51	ON	--	--	ON
80.00	1600	6-50	--	--	--	ON
79.20	1650	6-48	ON	ON	ON	--
79.90	1700	6-47	--	ON	ON	--
78.75	1750	6-45	ON	--	ON	--
79.20	1800	6-44	--	--	ON	--
79.55	1850	6-43	ON	ON	--	--
79.80	1900	6-42	--	ON	--	--
79.95	1950	6-41	ON	--	--	--
80.00	2000 ★	6-40	--	--	--	--

Remarks:

- ★ It means that this item is the factory default current.
- It means that this channel is OFF.

Optional accessories



(Model: BK-BAS017)

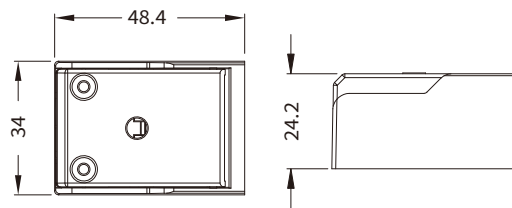

Unit:mm

Installation diagram of accessories

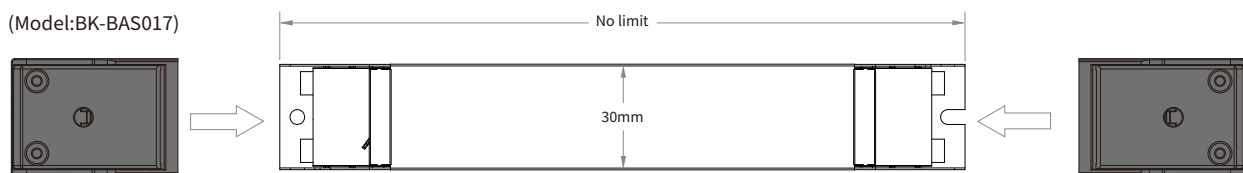

DALI dimming application

Wiring diagram

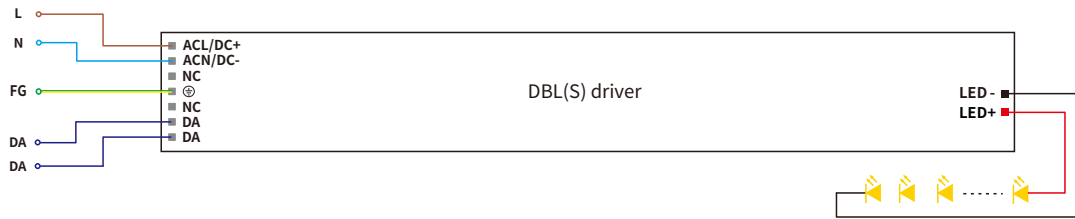

Switch to the DALI dimming mode

- After installation according to the wiring diagram of DALI dimming application, the driver will automatically switch to the DALI control mode after receiving any DALI command.

Remarks:

- Standard DALI control line voltage range: 9.5V to 22.5V, type 16V.
- The two DALI control lines polarity-reversible.
- Max. 64 DALI drivers per DALI control line.
- The maximum distance length of the DALI control line is 300m at $2 \times 1.5\text{mm}^2$.
- DALI bus can be wired together with any mains voltage cables, but separate wiring is recommended.
- The configuration parameters of the driver can be set through the DALI configuration tool or DALI application controller during installation, such as setting device address, group address, power-on level, bus-failure level, scene level, fade time, dimming curve, etc.

Please refer to the table below

Cable size	Distance
$2 \times 0.50\text{mm}^2$	max.100m
$2 \times 0.75\text{mm}^2$	max.150m
$2 \times 1.00\text{mm}^2$	max.200m
$\geq 2 \times 1.50\text{mm}^2$	max.300m

Power-on level :

When the driver is in DALI-2 dimming mode, the factory default level after each power-on is the brightest.

The power-on level can be set through the DALI configuration tool or DALI application controller during installation, and can be set to memory or fixed any brightness (such as off, darkest, 50%, etc.).

Note: The recommended setting for the default factory power-on level of the DALI-2 driver is the brightest in the DALI-2 standard.

Dimming curve

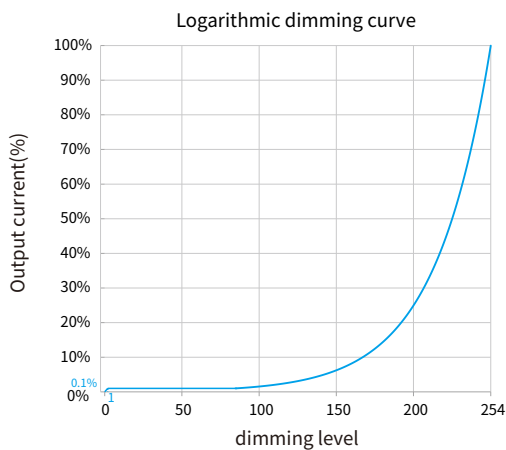

Remarks: The dimming curve can be selected by DALI configuration. The default is logarithmic dimming curve.

pushDIM dimming and color temperature application

Wiring diagram

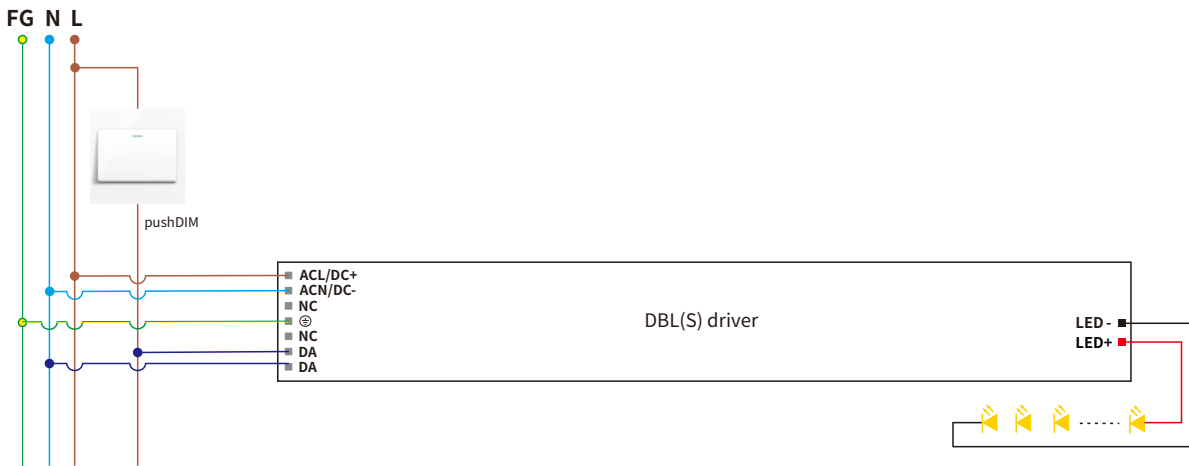

Switch to the pushDIM dimming mode

- After installation according to the wiring diagram of pushDIM dimming application, short press the pushbutton 5 times quickly within 3s , the driver will automatically switch to the pushDIM dimming mode.
- After switch to the pushDIM control mode, CorridorDIM mode will be automatically closed.

Remarks:

Max. 50 drivers per pushDIM control line.

Turn on or turn off:short press pushbutton for 0.2-1s.

Dimming: long press pushbutton for 1-5s.

Power on status: after power on,the light state will be the same as the lighting on state.

If the light is on before power on,the light will be on after power on again,brightness will be the same as the last lighting on brightness.

If the light is off before power off,the light will be off after power on again,short press the pushbutton,then the light will be on,the brightness will be the same as the last brightness.

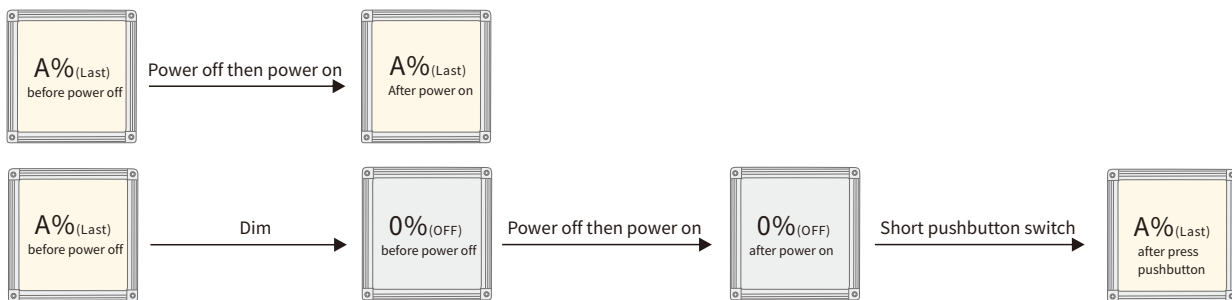

Multiple lights synchronize control operation

method 1:

Step 1:long press the pushbutton,confirm each light is on.

Step 2:short press the pushbutton,confirm each light is off.

Step 3:long press the pushbutton,confirm each light is from darkest to brightest and all the lights are synchronous.

method 2:

- Long press the pushbutton 15s,all lights output to the brightest state.

corridorDIM dimming and color temperature application

Wiring diagram

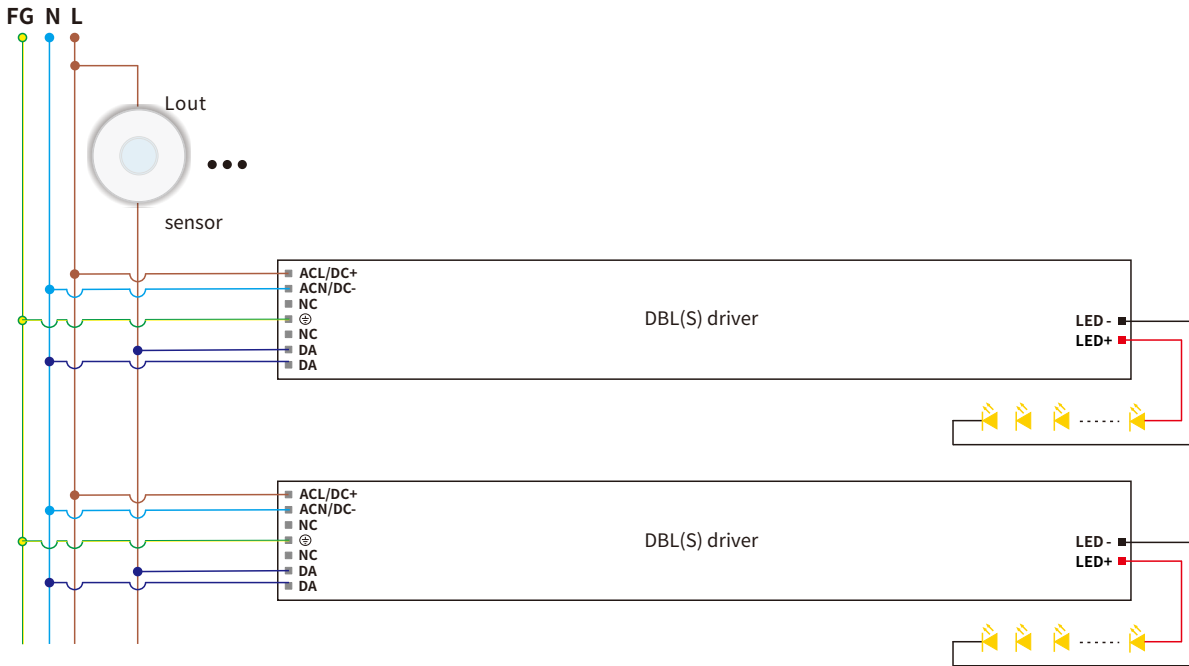

Switch to the corridorDIM dimming mode

- Method 1: Switch by sensor.

After installation according to the wiring diagram of corridorDIM dimming application, you can use the following two methods to switched.

Method 1: Keep the movement in the effective sensing area for 5 minutes, the corridorDIM dimming function of the driver will be switched and light up 100% (under the default setting).

Method 2: Switch by Hold-time

Set the hold-time of the sensor to more than 5 minutes. When the motion sensor detects a person and turns on the output for 5 minutes, the corridorDIM dimming function will be switched and the light will be on 100% (Default), finally restore the hold-time that the sensor actually needs.

-Method 2: Switch by normal switch

After installation according to the wiring diagram of the corridorDIM dimming application, first replace the sensor with a normal switch, and then turn on the normal switch for 5 minutes, and the driver will automatically switch to corridorDIM dimming mode, then remove the normal switch and replace it with the sensor.

- After switch to the corridorDIM dimming mode, the pushDIM dimming mode will be automatically deactivate .

Remarks

- During normal working,It is recommended to set the hold-time of the motion sensor to the minimum.
- Need to use a motion sensor with AC switch.

corridorDIM working process

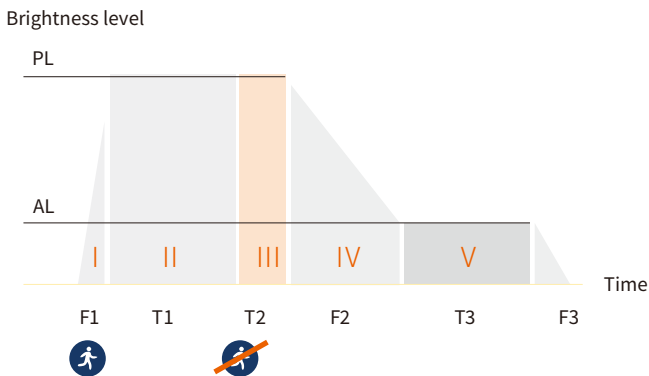

Name	Symbol	Factory setting	Settable range
Fade-in time	F1	1s	0-100s
Presence level	PL	100%	0-100%
Hold-on time	T1	By sensor setting	
Run-on time	T2	180s	0-60000s
Fade-out time	F2	5s	0-100s
Absence level	AL	10%	0-100%
Stand-by Time	T3	unlimited	0-59999s,60000s(unlimited)
Fade-off time	F3	0s	0-100s

- The parameters of corridorDIM can be set through the configuration tool.
- corridorDIM is not activated by default.

Device configuration

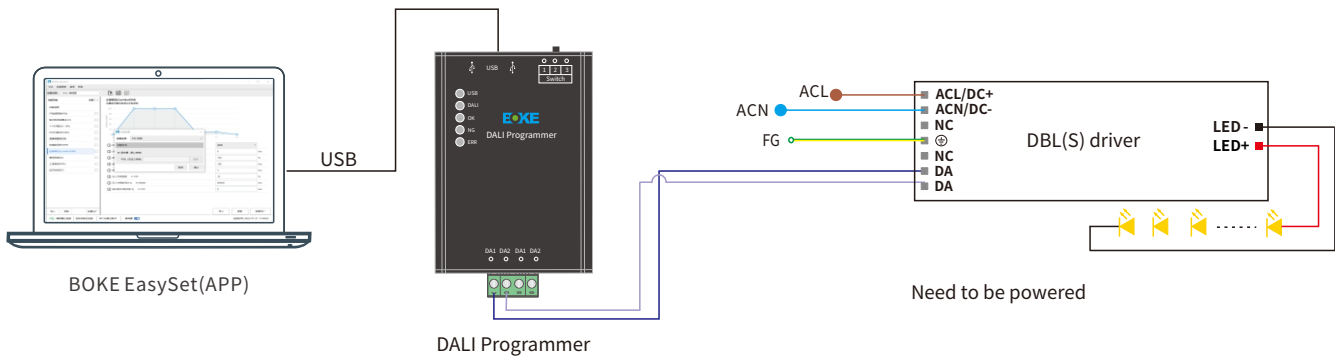

Software download(PC&mobile)



PC:Windows7/Windows10/Windows1132bit/64bit;
 Mobile:Androidsystem≥6.0, iossystem≥14.0.

Configure tools and software

Type	Name	Brand	Name	BOKE EasySet minimum version(PC)
Programmer	DALI programmer	BOKE	BK-CS01-SDL	V1.0.0
Software	PC Software	BOKE	BOKE EasySet	V1.0.0

Parameters configure

Configuration items	Factory settings	Parameter configuration	Read/Write
Product information	-	NO	Read Only
Adjustable output current(AOC)	Activated	YES	Read/Write
PUSH dimming(pushDIM)	Activated	YES	Read/Write
Corridor dimming(corridorDIM)	Activated	YES	Read/Write
Emergency lighting(EL)	Activated	YES	Read/Write
Power-on fadeing(POF)	Deactivated	YES	Read/Write
Constant light output(CLO)	Deactivated	YES	Read/Write
Hot plug-in protection(HPP)	Deactivated	YES	Read/Write
Run-time(RT)		NO	Read Only
DALI Address(DA)	Activated	YES	Read/Write
DALI basic parameters(DP)	Activated	YES	Read/Write
DALI scene setting(DS)	Activated	YES	Read/Write
Other parameters		YES	

Note: The default factory mode of emergency lighting is derated mode, and the emergency brightness is 15%

Mechanical Specification

Size(Excluding accessories)

Unit:mm

DBL040S-A/DBL050S-A

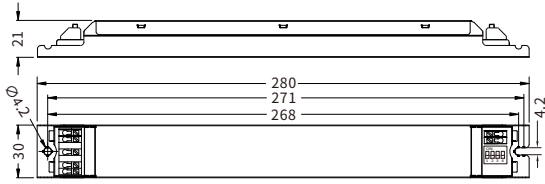

DBL060S-A/DBL080S-A

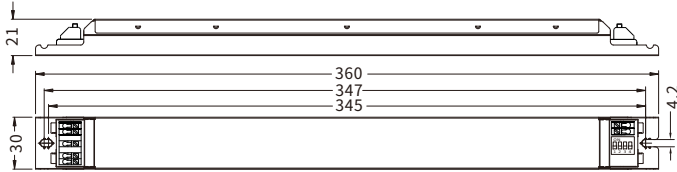

Mechanical Specification

Size(Include accessories)

Unit:mm

DBL040S-A/DBL050S-A

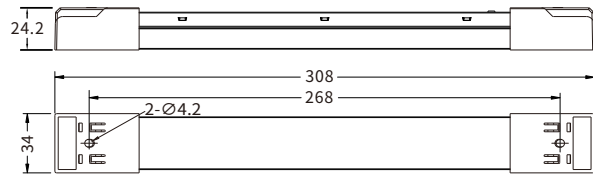

DBL060S-A/DBL080S-A

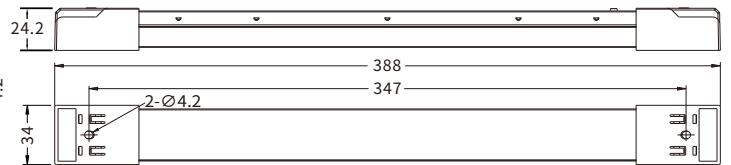

INPUT

Numbering	function	colour
1	ACL/DC+	grey
2	ACN/DC-	grey
3	NC	grey
4	FG	grey
5	NC	grey
6	DA/PUSH	grey
7	DA	grey

Input wire

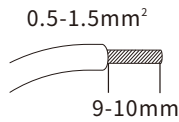

OUTPUT

Numbering	function	colour
1	LED-	black
2	LED+	red

Output wire

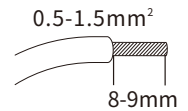

Installation note

Hot plug-in

- When the function is not enabled, hot plug-in is not supported due to residual output voltage of > 0 V.
- If a LED load is connected the device has to be restarted.
- Restart can be achieved by re-powering the driver or executing a on/off command (action) through the control interface.

Installation requirements

- The driver should be installed in a dry, acid-free, oil-free, fat-free environment.
- The installation ambient temperature of the driver shall not exceed the value of Ta at any time.
- The temperature of the mounting surface of the driver should be lower than the temperature of Ta.
- The driver should keep a certain distance from the heating stuff (such as the luminaire radiator).
- If the driver is used externally (it needs to be used with the accessories), the installation of the driver should also meet the following conditions:
 - 1.The driver should be a certain distance between the drivers, as shown in Figure 1.
 - 2.The driver keeps a certain distance from surrounding objects, as shown in Figure 2.

Wiring guidelines

- All connections must be kept as short as possible to ensure good EMI behaviour.
- Mains leads should be kept apart from LED Driver and other leads(ideally 5 – 10 cm distance).
- Max. length of output wires is 2 m.
- Incorrect wiring can damage LED modules.

Replace LED module

1. Mains off
2. Wait more than 5 seconds
3. Remove LED module
4. Connect LED module again

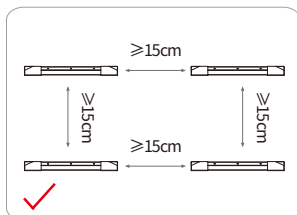
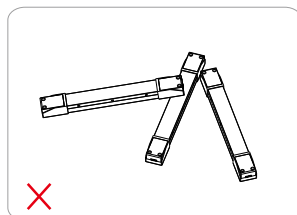

Figure 1

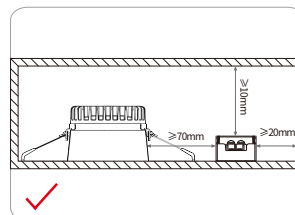

Figure 2

Packaging



Model	Product size	Weight	Packaging size	Carton size	Qty/carton	N.W	G.W
DBL040S-A	L280*W30*H21mm	190g	L300*W213*H78mm	L315*W220*H175mm	40pcs	7.60KG	9.01KG
DBL050S-A	L280*W30*H21mm	202g	L300*W213*H78mm	L315*W220*H175mm	40pcs	8.08KG	9.45KG
DBL060S-A	L360*W30*H21mm	265g	L375*W110*H78mm	L395*W240*H100mm	20pcs	5.30KG	6.65KG
DBL080S-A	L360*W30*H21mm	272g	L375*W110*H78mm	L395*W240*H100mm	20pcs	5.44KG	6.75KG

Accessories

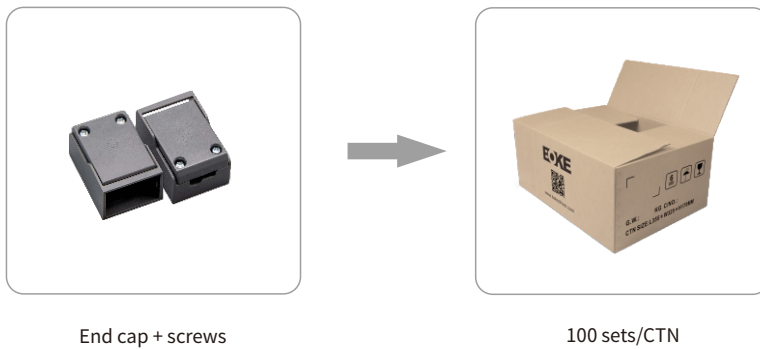

Model	Product size	Weight/set	Carton size	Qty/carton	N.W	G.W
BK-BAS017	L48.4*W34*H24.2mm	26g	L450*W350*H180mm	100 sets	2.6kg	3.2kg

Additional information

1. The life and MTBF of the product are for reference only, and do not represent a warranty statement.
2. For more information, please send an email to info@bokedriver.com.